

**ANIMATED  
ENVIRONMENT  
PROPOSAL**

**BY: KAMI NELSON**

**COMPUTER ANIMATION  
FOR MULTIMEDIA &  
WEB | IMD222**

## CONCEPTS

### CONCEPT 1 - MYSTERIOUS PLUTOPIA

The background setting of this animated environment would be set on Pluto and in the background you can see outer space and two of the moons of Pluto. The stars will twinkle and other galaxies seen in the distance will float and swirl along with the colors move to the right very gradually as to show that the Pluto is rotating. There will a spaceship or maybe two, an alien, satellite and a few other characters who will be moving around on the rough crater ridden terrain of Pluto.

### CONCEPT 2 - THE FORBIDDEN JUNGLE

The background setting of this animated environment would be set in the jungle. There would be trees with vines, exotic flowers with bright colors and lots of ferns and green plants. A monkey will swing through the trees. A butterfly will flutter through and land on the flowers. There will also be a parrot set in the trees that flaps its wings and looks around. Possible an elephant will peak out and raise his trunk.

### CONCEPT 3 - COLD WARRIORS

The background setting of this animated environment would be set at the edge of a glacier. There will be floating pieces of ice floating around in the water and clouds moving over the setting sun. There will be penguins that waddle around and seals that come out of the water up onto the glacier. The other characters could be fish jumping up out of the water and maybe a polar bear.

### CHOSEN CONCEPT:

I had a hard time choosing between the Cold Warriors and Mysterious Plutopia, both are very interesting to me so I am a little torn between the two, but felt that the Plutopia might be a little easier for me to draw.

### CONCEPT 1 - MYSTERIOUS PLUTOPIA



# MYSTERIOUS PLUTOPIA

## ENVIRONMENT

The setting for my animation is on the surface of Pluto. There will be craters and ridges to create depth and some realism. The style of my environment and characters will be cartoonish and colorful.

Parts of the background that will be animated will be the stars twinkling and two moons in the background rotating with very light clouds moving through the background. There will also be spaceships flying in the distance. Clusters of stars like other galaxies will also be visible and will swirl.

## CHARACTERS

The visual style of the cartoons will match the style of the background. There will be a combination of a few simple characters and few other more complex characters.

**“Kipper” - the alien:** Will be a cute but unusual looking character. He will move kind of like a snail but faster. He has a blob like body with two arms and two tentacles that help him to slither across the ground. He has one big eye and four eyes that stick out above his head. All his eyes will move and have eyelids. The eyes above his head, his arms and his eyes will all be animated.

**Spaceship:** The spaceship will have rockets on the end that will shoot out fire - creating smoke. It will fly through the air and land on the surface of Pluto. As it begins to land legs will come down, 2 from the back and 1 from the front. The astronaut will then descend from the spaceship to land on the planet.

**“Hurley” - the astronaut:** Will look like a human with hands and feet but will be in a space suit. He will have a helmet and be tethered to the ship. When he walks he will bounce across the scene. The arms and face will be animated, showing surprise when he sees the alien.

**Satellite:** The satellite will float around in the sky and the solar panels on both sides will rotate up and down. The dish on top of the satellite will move side to side and up and down.

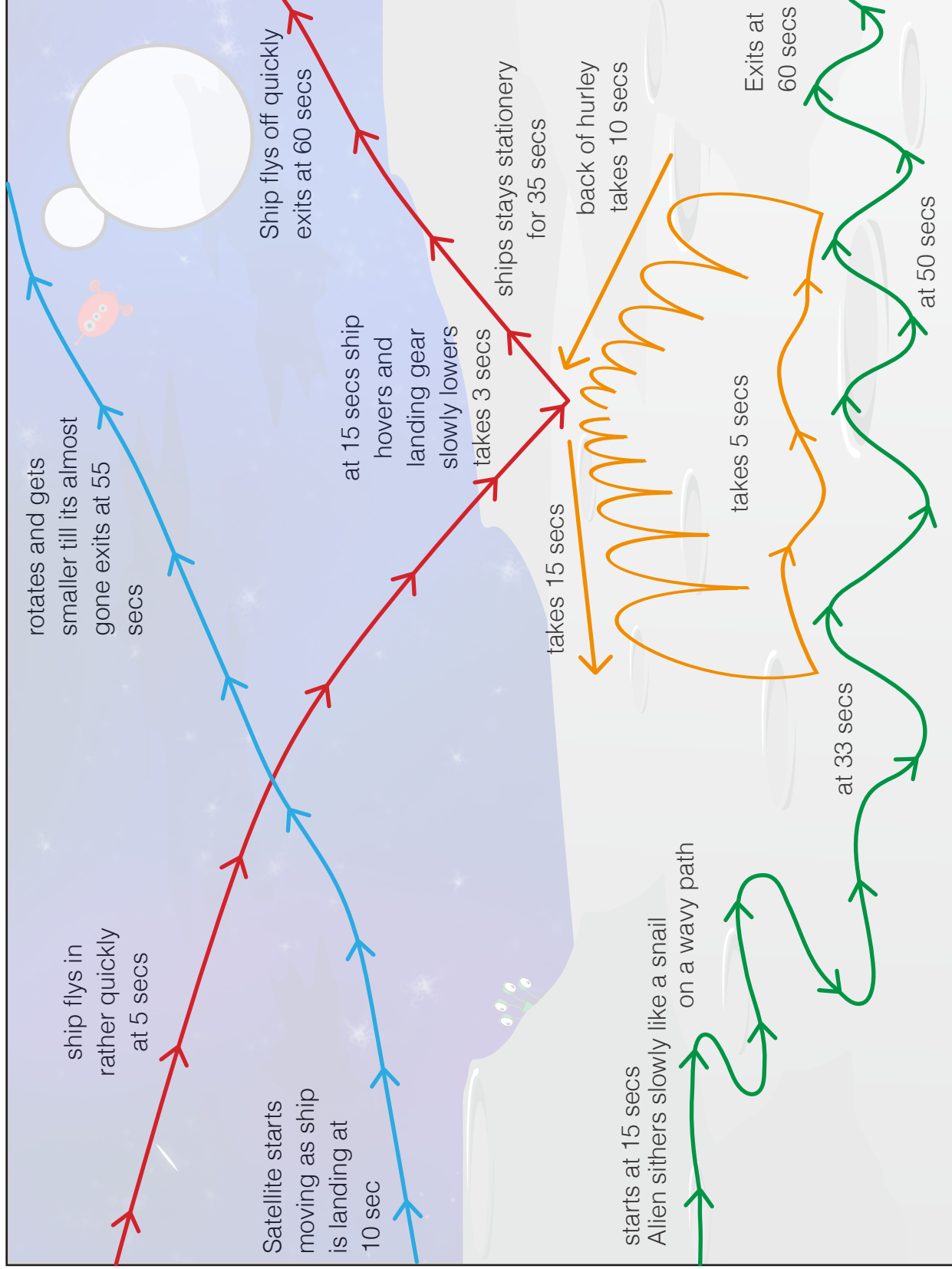

**NOTES:**

- Alien "Kipper" - Emerges from behind rocks, moves slowly and in a wavy pattern toward Hurley
- Astronaut "Hurley" - Exits ship hops toward front sees alien, gets scared returns to ship quickly.
- Spaceship - Flies into scene landing gear comes down & lands. Hurley returns ship flies out right.
- Satellite - Moves at a steady pace spinning and getting smaller the farther way it gets.



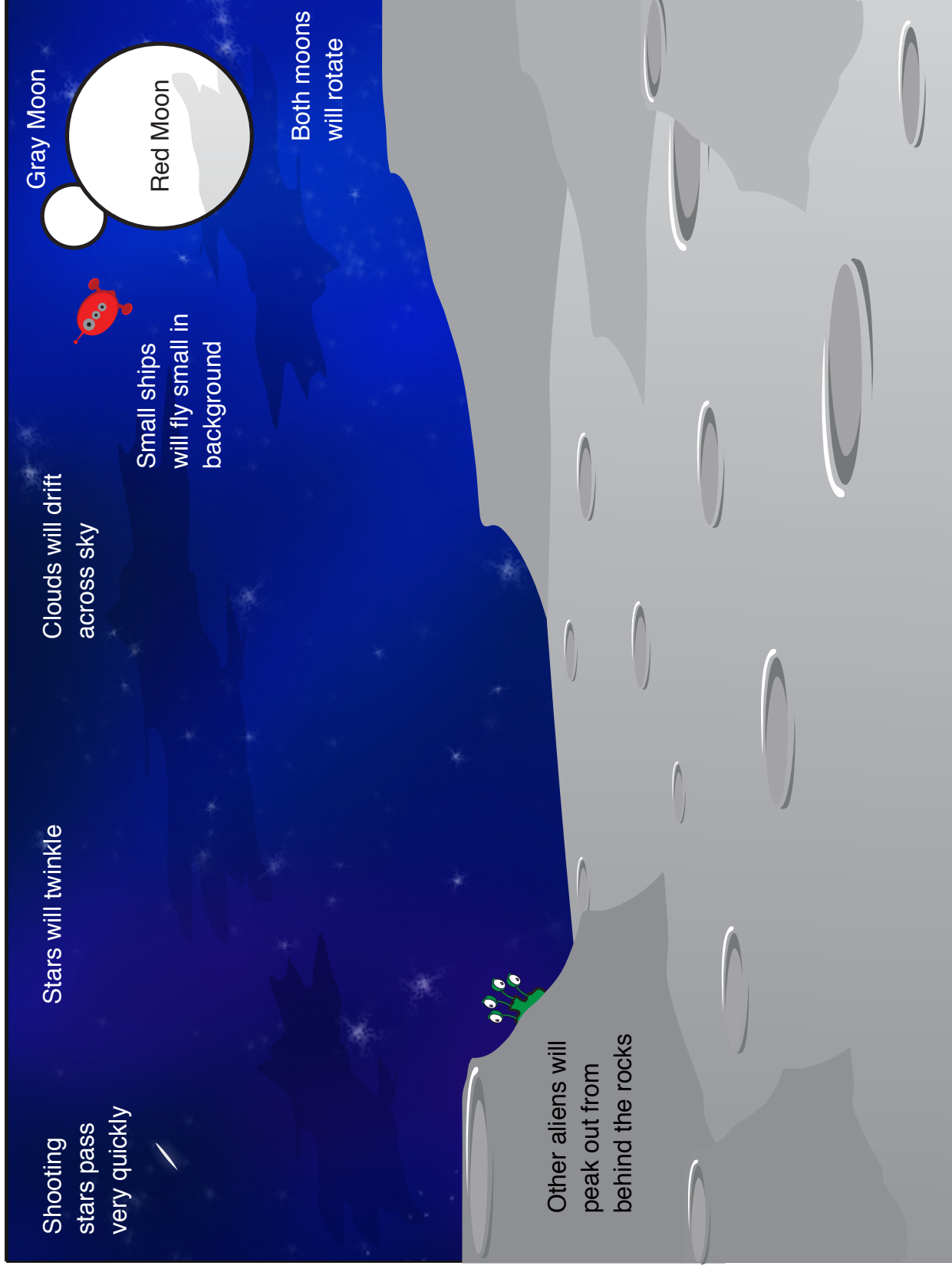

**NOTES:** Surface is shades of gray and has multiple layers to create depth on the planet and within the scene.

Stars and shooting stars twinkle and shoot across the scene.

Spaceships will fly around in background very small and fly creating depth of the open space in the background.

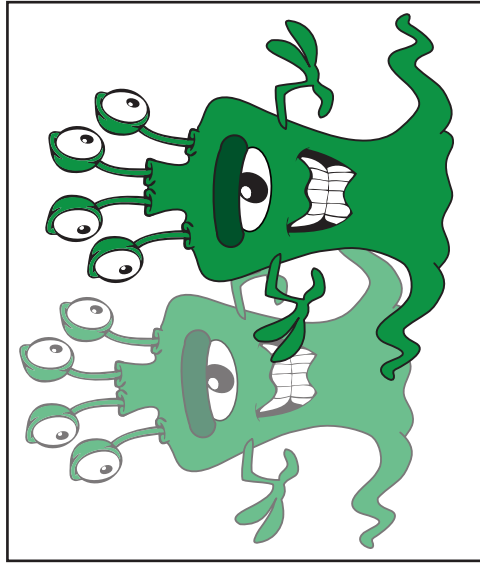

**Notes:** Alien moves with slither like a snail and moves slowly like a snail but a little faster.

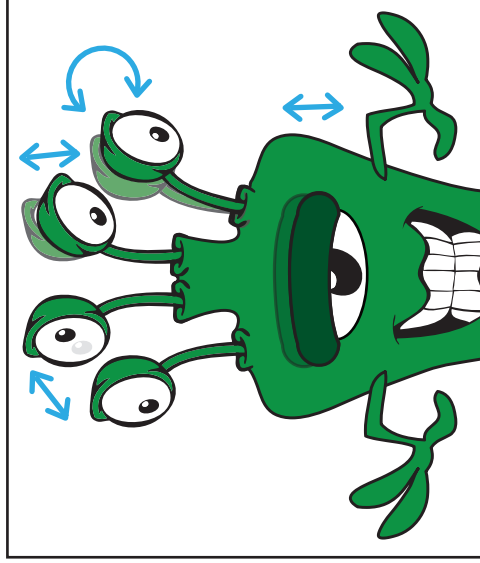

**Notes:** Eyes, eye balls, eye lids, and eye brows all move. Eyes lids and eye balls move to help show emotion. Eye balls rotate to look around.

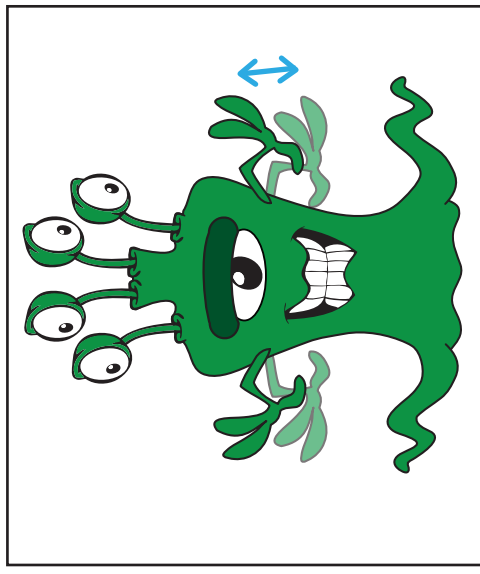

**Notes:** Arms move up and down to react to situations.

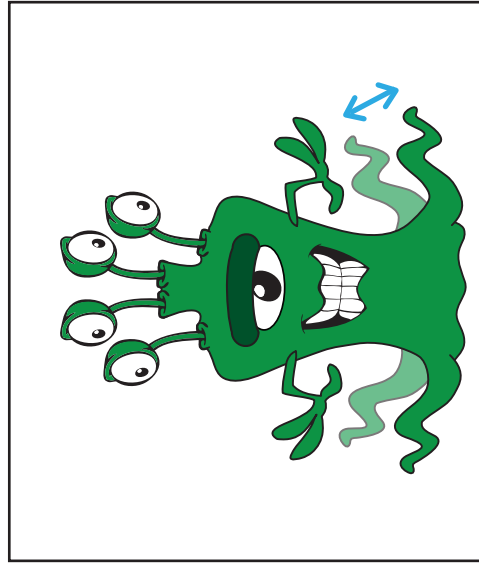

**Notes:** Tenticals can move up and down as well to help with movement.

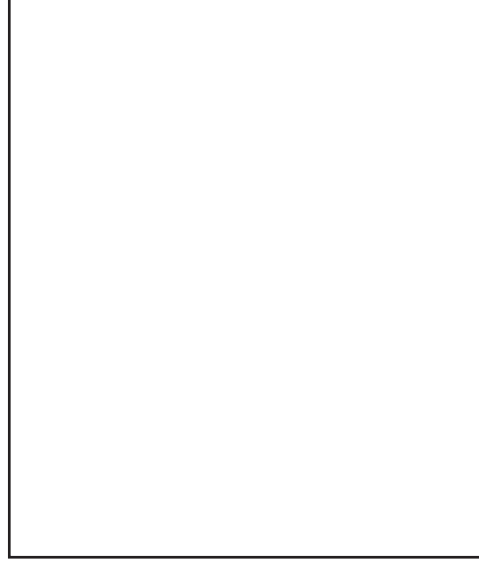

**Notes:**

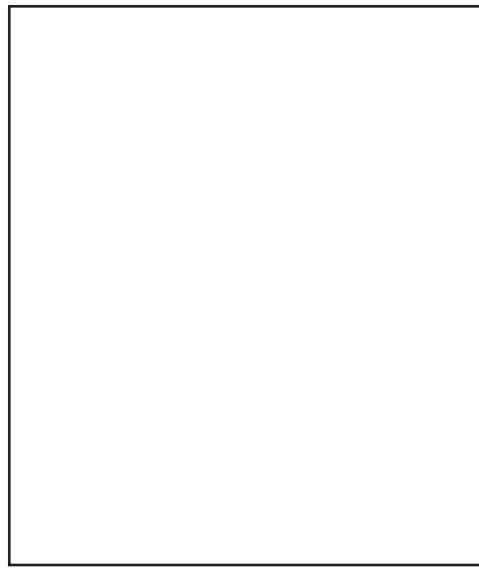

**Notes:**

# CHARACTER STORYBOARD - "HURLEY" THE ASTRONAUT

KAMI NELSON

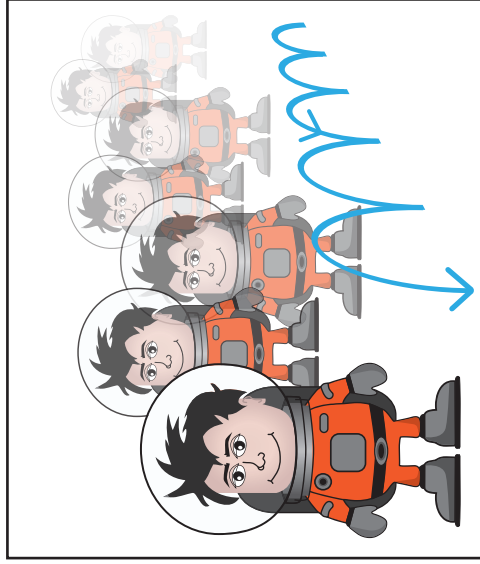

**Notes:** When Hurley moves he will hop since this is how astronauts move when in outerspace

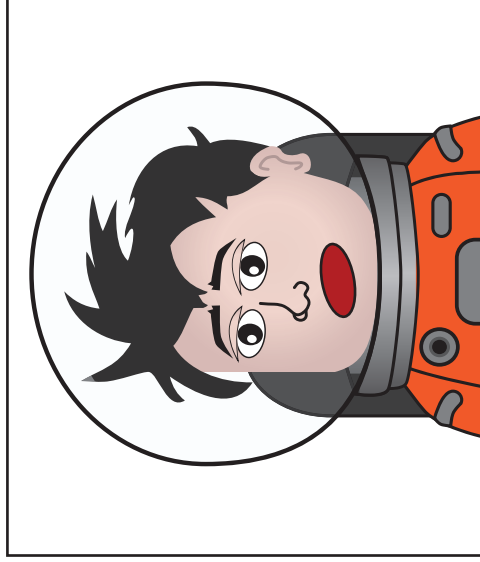

**Notes:** Mouth, eye lids, eye brows and all move to create a facial expression of surprise

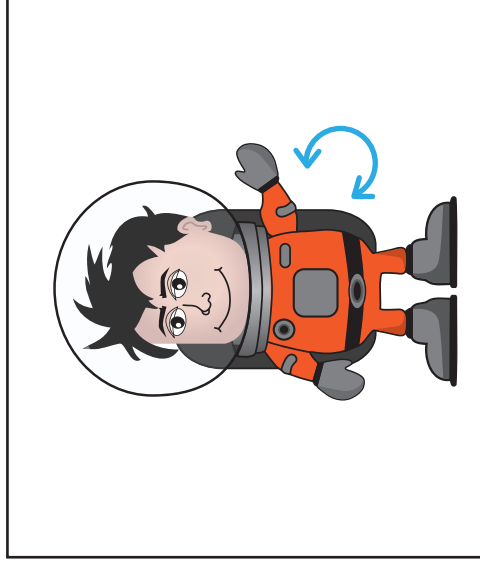

**Notes:** Arms can move and wave, etc if necessary.

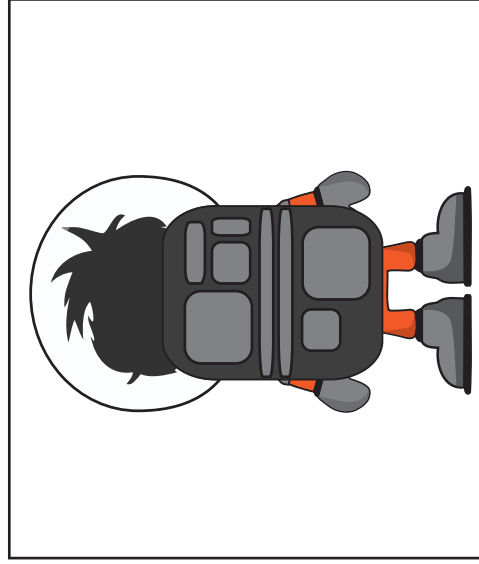

**Notes:** Back of astronaut when he retreats.

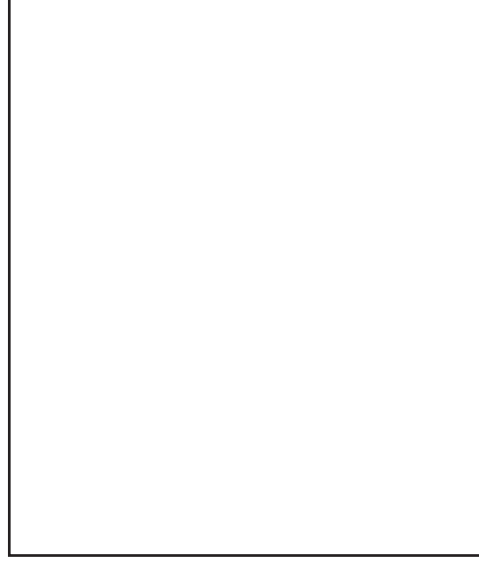

**Notes:**

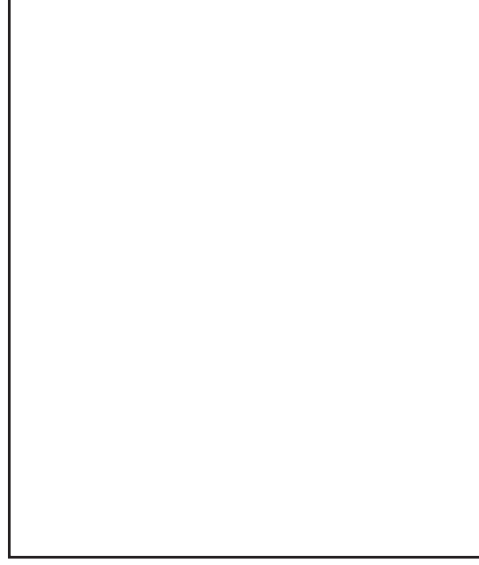

**Notes:**



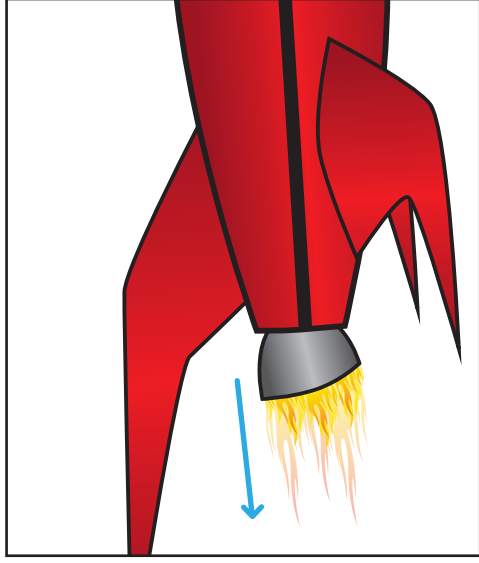

**Notes:** Flames on back of ship get longer and flicker to different lengths etc. to show that its being powered.

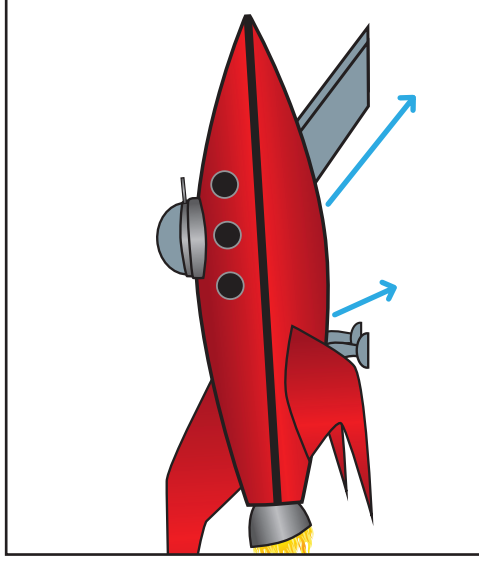

**Notes:** As ship lands landing gear will lower from bottom of spaceship.

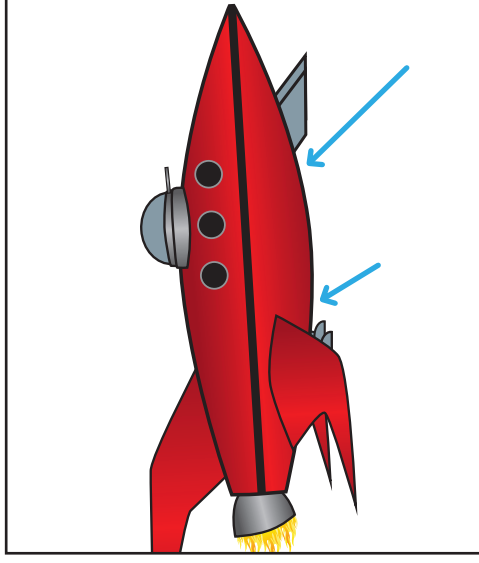

**Notes:** As ship takes off landing gear will raise and go back up into bottom of spaceship.

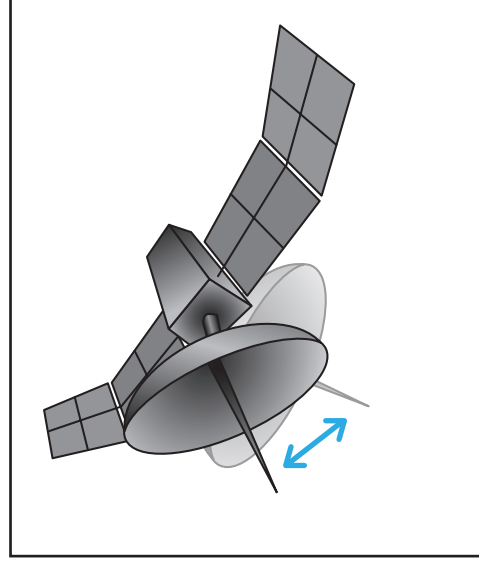

**Notes:** Dish moves up and down.

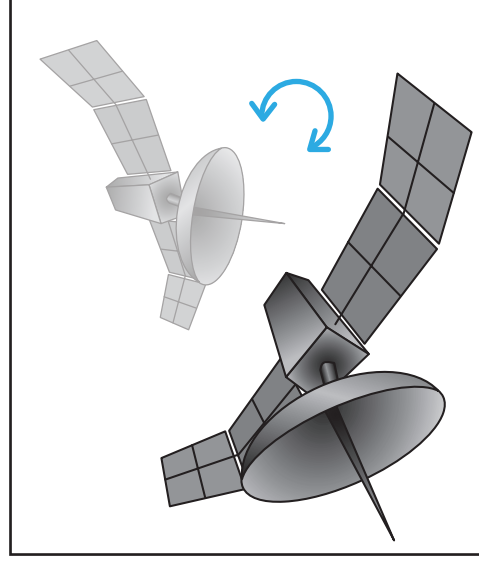

**Notes:** Satellite rotates as it flies.

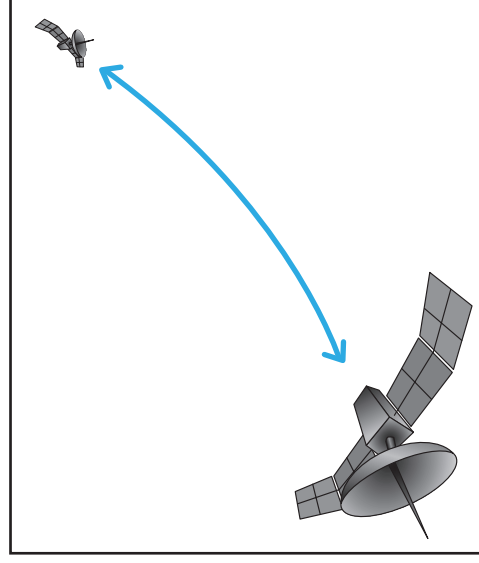

**Notes:** Moves on a smooth curved path and gets smaller as it moves away from scene.